

Front Suspension:

Ride Height: _____
Camber: _____
Toe: _____
Anti-Roll Bar: _____
Arm Type: _____
Tower Type: _____
Wheel Hex: _____
Steering Block KPI: _____
Caster Block Insert: 0 +2.5 +5
Bulkhead Type: _____
Kick-Up Angle: -2.5 0 +2.5
Steering Stop Spacing: _____
Caster Block Spacing: Fwd Back
Notes: _____

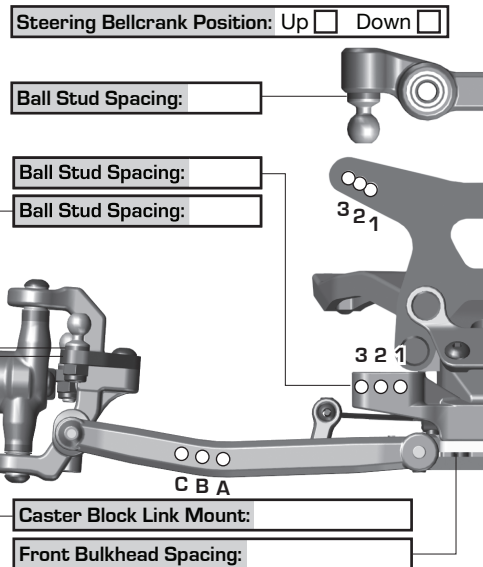
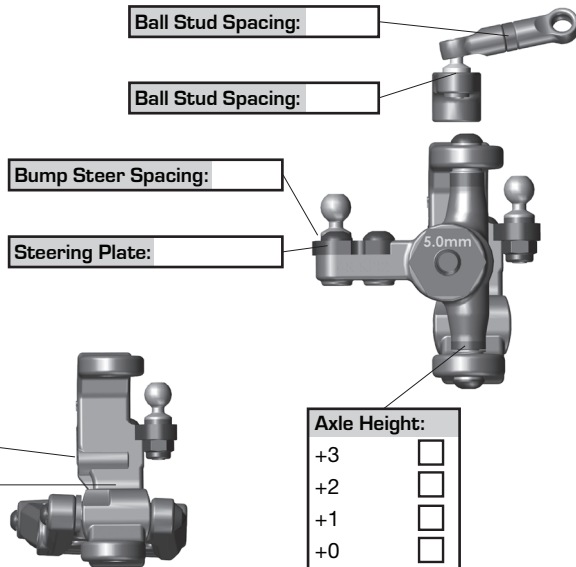

Rear Suspension:

Ride Height: _____
Camber: _____
Anti-Roll Bar: _____
Arm Type: _____
Tower Type: _____
Arm Spacing: Fwd Mid Back
Wheel Hex: _____
Hub Type: Std HRC
Hub Spacing: Fwd Mid Back
Drive Shaft: CVA's Universals
Notes: _____

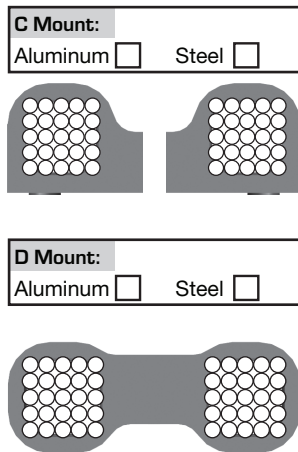

Axle Height:	
<input type="radio"/> ▼0 3 ▲	+3
<input type="radio"/> ▼1 2 ▲	+2
<input type="radio"/> ▲1 2 ▼	+1
<input type="radio"/> ▲0 3 ▼	+0

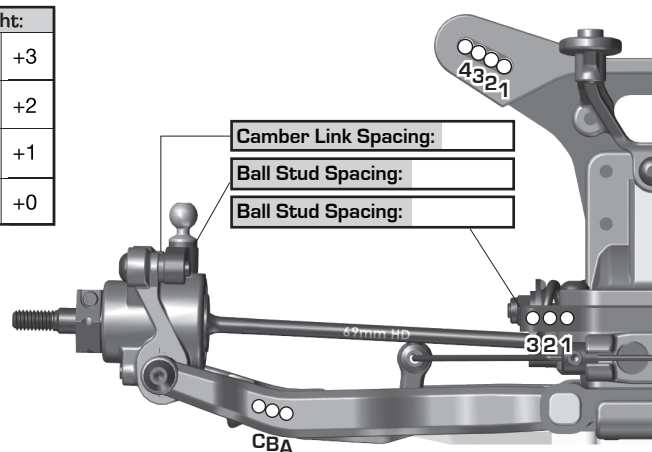

Electronics:

Radio: _____ Servo: _____
EPA: Throttle: _____ % Brake: _____ %
ESC: _____
ESC Settings: _____
Motor / Wind: _____ Timing: _____
Pinion: _____ Spur: _____
Battery Mount: Std Offset
Back 1 2 3 4 5 Forward
Battery: _____ Weight: _____
Notes: _____

Drivetrain:

Differential: Ball Diff:
Height: _____ Gear Diff:
Diff Setting: _____
Notes: _____

Slipper Clutch:

Type: _____
of Pads: _____
Setting: _____
Notes: _____

Shocks:

	Front	Rear
Piston:	_____	_____
Thickness:	_____	_____
Fluid:	_____	_____
Spring:	_____	_____
Limiters: Int: _____ Ext: _____ Int: _____ Ext: _____		
Stroke:	_____	_____
Eyelet:	_____	_____
Cup Offset: 0 <input type="checkbox"/> +5 <input type="checkbox"/> +9 <input type="checkbox"/> 0 <input type="checkbox"/> +5 <input type="checkbox"/> +9 <input type="checkbox"/>		
Kashima Bodies: <input type="checkbox"/> Chrome Shafts: <input type="checkbox"/> Machined Spacers: <input type="checkbox"/>		
Notes:		

Stroke

Track Info:

Size: _____
Surface: _____
Traction: _____
Moisture: _____
Condition: _____
Temperature: _____
Notes: _____

Tires:

Front Tires: _____
Front Compound: _____
Front Insert: _____
Rear Tires: _____
Rear Compound: _____
Rear Insert: _____
Wheel (F/R): _____
Notes: _____

Body, Weight:

Body: _____
Front Wing: _____
Rear Wing: _____
Wing Angle: 0° 3° 6°
Chassis Length: _____
Servo Weights: _____
Electronic Weights: _____
Total Vehicle Weight: _____

Vehicle Comments:

Notes: _____

